

# Owner's Manual with Installation Instructions

## **Banks Monster® Exhaust System Dual-Tip**

**2007-2009 Dodge 6.7L Cummins  
ISB Pickup Trucks  
Including Mega Cab**

**2010 Dodge 6.7L Cummins  
6'4" Short Bed Only**

THIS MANUAL IS FOR USE WITH  
MONSTER EXHAUST, SYSTEMS 49766

Gale Banks Engineering  
546 Duggan Avenue • Azusa, CA 91702  
(626) 969-9600 • Fax (626) 334-1743

Product Information & Sales: (888) 635-4565  
Customer Support: (888) 839-5600  
Installation Support: (888) 839-2700

**bankspower.com**



# General Installation Practices

Dear Customer,

If you have any questions concerning the installation of your Banks Power System, please call our Technical Service Hotline at (888) 839-2700 between 7:00 am and 4:00 pm (PT). If you have any questions relating to shipping or billing, please contact our Customer Service Department at (888) 839-5600.

Thank you.

**1.** For ease of installation of your Banks system, familiarize yourself with the procedure by reading the entire manual before starting work.

**2.** The general assembly diagram (**Figure 1**) provides only general guidance. Refer to each step and section diagram in this manual for proper instruction.

**3.** Throughout this manual, the left side of the vehicle refers to the driver's side, and the right side to the passenger's side.

**4.** Disconnect the ground cable from the battery (or batteries, if there are two) before beginning work.

**5.** Route and tie wires and hoses a minimum of 6" away from exhaust heat, moving parts and sharp edges. Clearance of 8" or more is recommended where possible.

**6.** When raising the vehicle, support it on properly weight-rated safety stands, ramps or a commercial hoist. Follow the manufacturer's safety precautions. Take care to balance the vehicle to prevent it from slipping or

falling. When using ramps, be sure the front wheels are centered squarely on the topsides; put the transmission in park; set the hand brake; and place blocks behind the rear wheels.

**Caution! Do not use floor jacks to support the vehicle while working under it. Do not raise the vehicle onto concrete blocks, masonry or any other item not intended specifically for this use.**

**7.** During installation, keep the work area clean. Do not allow anything to be dropped into intake, exhaust, or lubrication system components while performing the installation, as foreign objects will cause immediate engine damage upon start-up.

## Tools Required:

- 1/2" and 3/8" drive ratchets with inch and metric sockets and 1/2" and 3/8" drive extension
- Inch and metric combination or open-end wrenches
- Standard screwdriver
- Clean shop towels or rags
- Pry-bar

## Highly recommended tools and supplies:

- Inch-pound and foot-pound torque wrenches
- oxy-acetylene torch
- Penetrating oil or light lubricant spray
- Reciprocating saw

# Also Available from Banks Power

## 07-10 Dodge 6.7L



### **Banks Ram-Air Intake System** (**'07-09 P/N 42175**), (**'10-12 P/N 42180**)

- Increases your airflow over stock.
- Adds power, improves fuel economy, lowers EGTs and reduces smoke.

### **Banks Ram-Air Intake Super-Scoop** (**P/N 42190, 42191**)

- Adds cooler denser air to the Ram-Air Intake housing, further increasing fuel economy, reducing smoke and lowers EGTs.

### **Banks Techni-Cooler® System** (**'07-08 P/N 25983**), (**'09 P/N 25985**)

- Provides increased air flow to the engine by increasing air density for more increased power, lower EGTs and improved fuel economy.

### **Banks AutoMind Programmer** (**'07-09 P/N 66108**)

- Clear and view OBDII Diagnostic Trouble Codes (DTC).
- Loaded with dyno-proven tuning files
- Speed Limiter adjustment capabilities
- Recalibration of the speedometer
- Customize and adjust gearing, tire size and fuel octane

For More Information please call (888) 635-4565  
or Visit us online @ [www.bankspower.com](http://www.bankspower.com)

# General Assembly Diagram

Figure 1

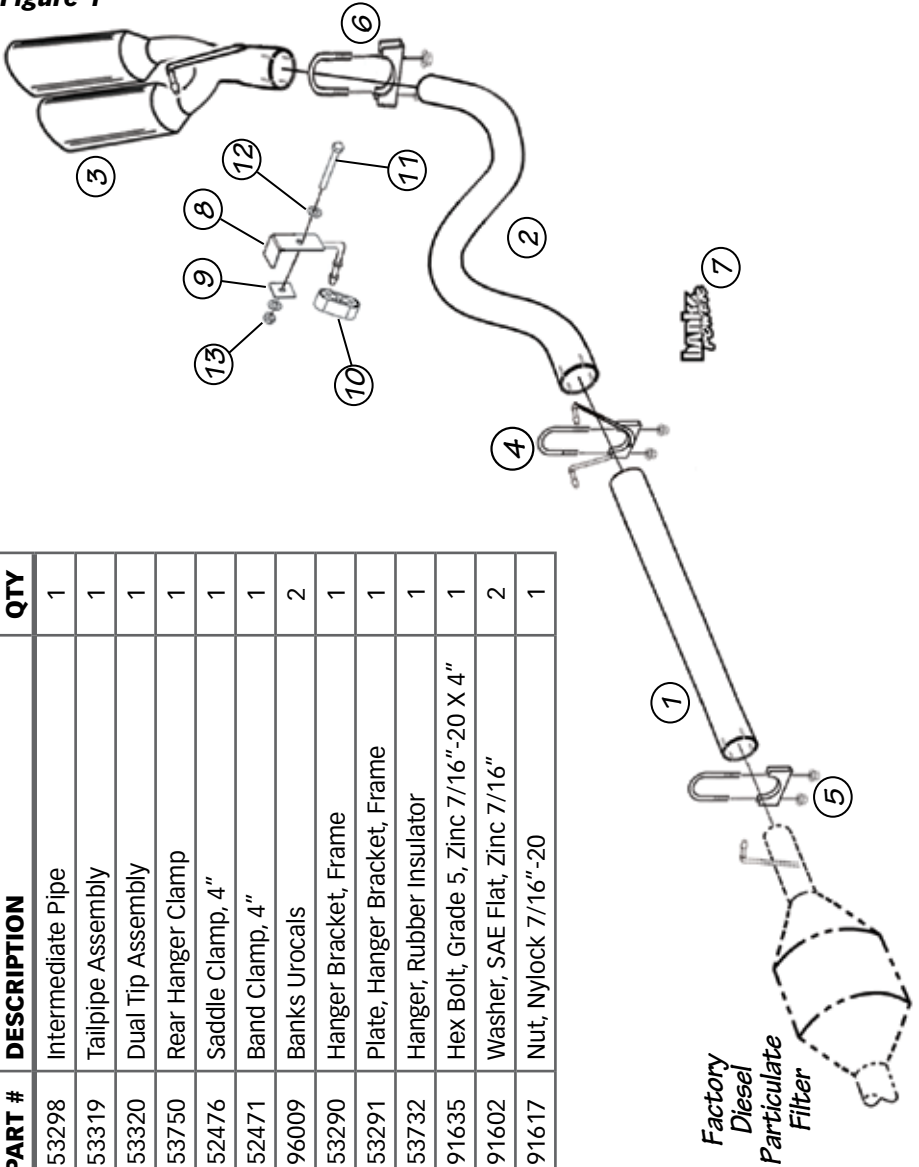

ITEM #	PART #	DESCRIPTION	QTY
1	53298	Intermediate Pipe	1
2	53319	Tailpipe Assembly	1
3	53320	Dual Tip Assembly	1
4	53750	Rear Hanger Clamp	1
5	52476	Saddle Clamp, 4"	1
6	52471	Band Clamp, 4"	1
7	96009	Banks Uroicals	2
8	53290	Hanger Bracket, Frame	1
9	53291	Plate, Hanger Bracket, Frame	1
10	53732	Hanger, Rubber Insulator	1
11	91635	Hex Bolt, Grade 5, Zinc 7/16"-20 X 4"	1
12	91602	Washer, SAE Flat, Zinc 7/16"	2
13	91617	Nut, Nylock 7/16"-20	1

# Monster Exhaust System Installation

1. As a precaution, disconnect the ground of the battery (if there is more than one battery, disconnect both).
2. Raise the vehicle and support it with properly weight rated safety stands, ramps or a commercial hoist. Follow the manufacturer's safety precautions. Take care to balance the vehicle to prevent it from slipping or falling. When using ramps, be sure the front wheels are centered squarely on the topsides; place the transmission in park; set the parking brake and place blocks behind the rear wheels.

**CAUTION: DO NOT WORK UNDER ANY VEHICLE SUPPORTED ONLY BY A JACK. SEVERE INJURY MAY RESULT.**

**WARNING! The following step may require the use of a torch and/or saw. Proper safety equipment should be used. Failure to use proper safety equipment may result in severe injury.**

3. Starting at the rear of the vehicle, remove the tailpipe at the muffler outlet by cutting through the connection or by removing the clamps and heating the joints with an oxy-acetylene torch to allow crimped pipes to separate. Remove the tailpipe from the vehicle.

4. Loosen and remove the clamps on the outlet of the Diesel Particulate Filter to the front intermediate pipe.

**TAKE CAUTION TO NOT CUT OR DAMAGE DIESEL PARTICULATE FILTER TUBING DURING THE REMOVAL PROCESS.**

Separate the intermediate pipe to Diesel Particulate Filter connection. Remove the intermediate pipe and muffler assembly from the vehicle.

*NOTE: the use of an oxy-acetylene torch may be necessary. Remove the muffler hanger pins from the rubber hangers with a pry bar (Spray lubricant will ease hanger removal) and remove the intermediate pipe and muffler assembly from the vehicle.*

5. Locate the supplied intermediate pipe and cut the intermediate pipe based on the following configurations. See **Table 1**. Cut the NON-swaged end of the intermediate pipe. See **Figure 2**.
6. Install a 4" exhaust clamp onto the front of the Banks intermediate pipe. Install the intermediate pipe onto the Diesel Particulate Filter outlet. Loosely snug the 4" clamp.
7. Install the rear hanger clamp onto the intermediate pipe outlet with the hanger pins facing the front of the vehicle. Insert the two (2) hanger pins into the rear rubber hangers and adjust the hanger clamp to a position that best supports the intermediate pipe. (see **Figure 3**).
8. Route the tailpipe over the rear axle housing and into the intermediate pipe outlet. Loosely snug the hanger clamp on the intermediate pipe outlet.
9. Install the Banks hanger brackets onto the rear passenger-side frame rail behind the rear shock cross member. Place the hanger bracket over the frame rail on the inside. Align the hole in the center of the frame with the hanger bracket. Install the  $\frac{7}{16}$ " bolt and washer through the bracket and frame rail. Secure the bolt on the outside frame rail using the 2" x 2" plate,  $\frac{7}{16}$ " washer, and  $\frac{7}{16}$ " nut. Be sure the hanger pin is parallel with the frame rail and torque all hardware to 48 ft-lb (see **Figure 4**).

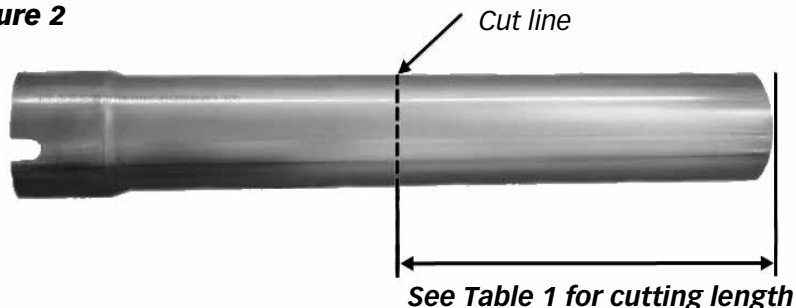
**Figure 2****Table 1**

<b>2007-2009 Dodge 6.7L Cummins</b>		
	Wheel Base 2007-2009	Cut this length from the Intermediate Pipe. See <b>Figure 2</b> .
Mega Cab/ Short Bed	160.5"	No Cut
Quad Cab/ Long Bed	160.5"	No Cut
Quad Cab/ Short Bed	140.5"	21.75"
Regular Cab/ Long Bed	140.5"	21.75"
<b>2010 Dodge 6.7L Cummins</b>		
	Wheel Base 2010	Cut this length from the Intermediate Pipe. See <b>Figure 2</b> .
Crew Cab/ Short Bed	149.5"	12"

**10.** Install the supplied rubber insulators onto the Banks hanger brackets.

**11.** Un-clip the axle vent hose outlet attached to the bed. Re-route the vent hose on top of the fuel tank and attach to the bed. Zip tie the vent hose and brake line to the emergency brake cable, away from the tailpipe.

**12.** Be sure that the tailpipe is completely engaged into the intermediate pipe. Rotate the tailpipe until the hanger pins are parallel with the frame-mounted pin.

*NOTE: Recommended distance between exhaust tip and body is a half (1/2") inch.*

**13.** Install a supplied exhaust clamp on the outlet of the tailpipe. Install the Dual tailpipe tip on the tailpipe. Install hanger into rubber insulator. Keep the wrapping on until installation is complete. Adjust the tip past the edge of the body or where aesthetically pleasing.

**14.** Adjust each of the pipes to ensure that all of the hanger pins are parallel with the frame-mounted pins and fully inserted in the vehicle's rubber insulators. See **Figure 3**.

**15.** With everything positioned properly, begin to tighten the clamps starting with the ones closest to the turbo and working your way back. Evenly torque the exhaust clamps to

**Figure 3**

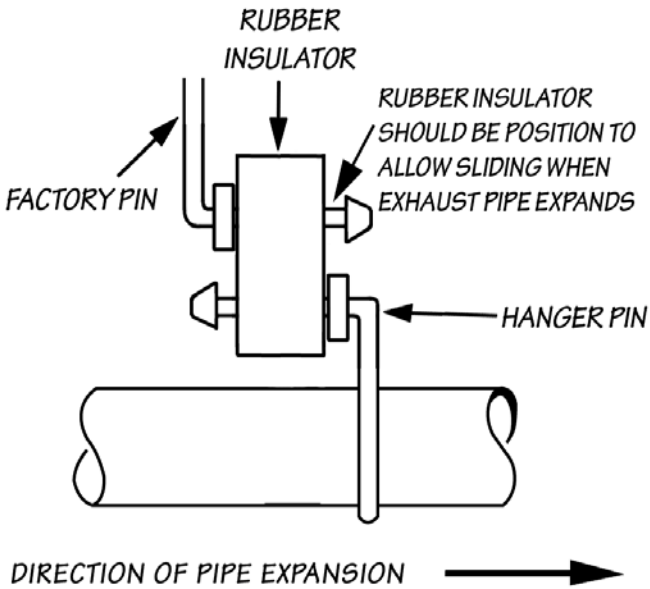

**Figure 4**

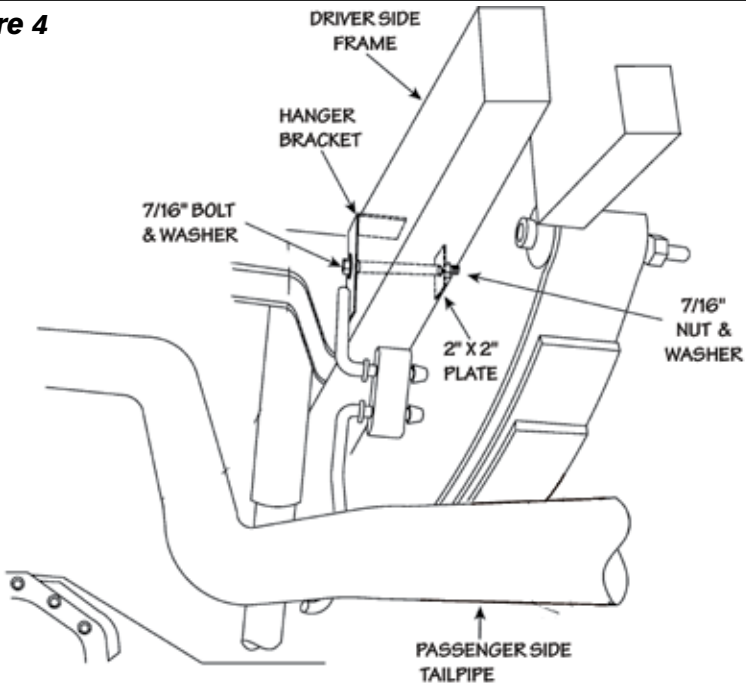

# Dodge 6.7L Cummins Banks Monster Exhaust System Dual-Tip

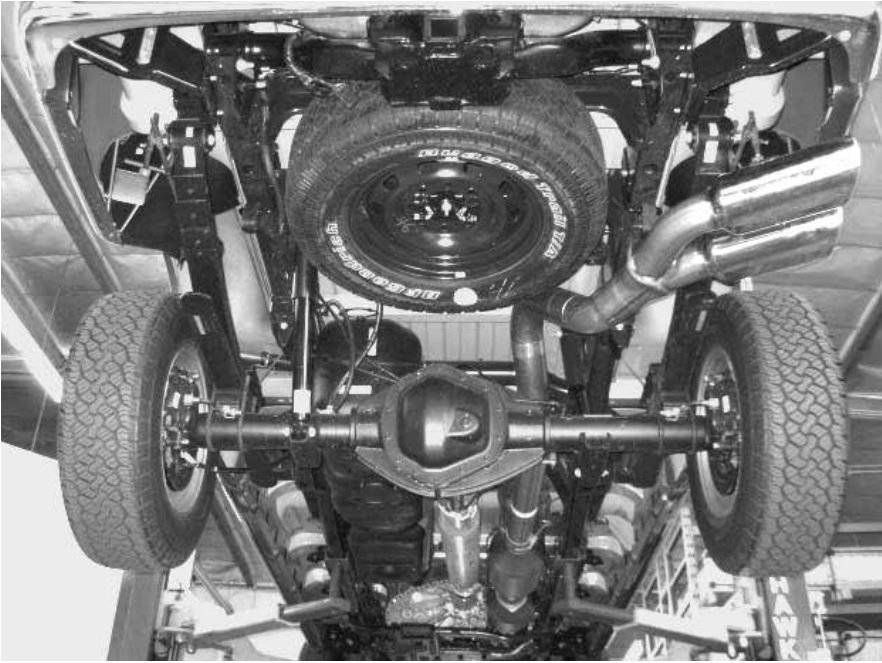

35 ft-lbs. Make sure that each slip is fully inserted (+/- ¼ inch).

**16.** Remove the protective covering from the tailpipe tip.

**Caution: The protective covering may ignite and burn if not removed prior to running the engine.**

**17.** Your system includes two (2) Banks power logos. The logos can be mounted ½" to 1" above the "Cummins Turbo Diesel" emblem on the driver-side and passenger-side

front fenders.

**18.** Re-connect battery terminals if previously removed.

**Banks Monster Exhaust installation is now complete.**

Gale Banks Engineering  
546 Duggan Avenue • Azusa, CA 91702  
(626) 969-9600 • Fax (626) 334-1743

Product Information & Sales: (888) 635-4565  
Customer Support: (888) 839-5600  
Installation Support: (888) 839-2700

**bankspower.com**